

# THE BETA 900

## - MODEL 7F -

### FLOUR TORTILLA MACHINE

Optional  
Dough Trolley Loader

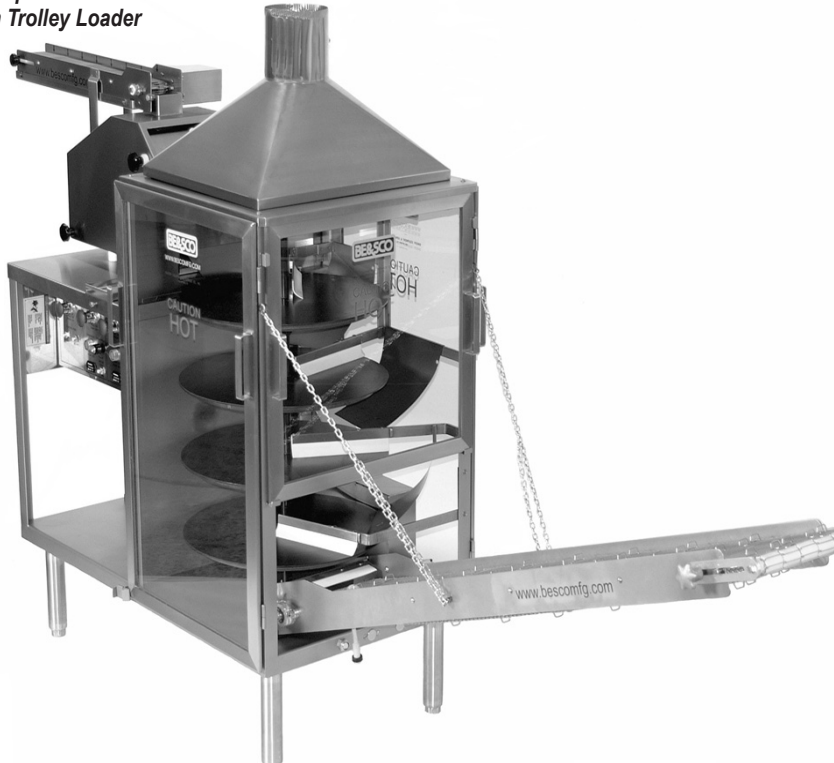

- *The Ultimate In Display Cooking!*
- *Energy Efficient!*
- *Easy to Operate!*
- *A Unique Machine Offering Versatility and Consistency!*
- *Customize it to fit in your facility!*



Right Side Exit



Left Side Exit



#### SPECIFICATIONS

Electric: 240V,60Hz,17 amps,  
Single Phase

Natural Gas: 45,000 BTU's

Liquid Propane: Optional  
(LP version not UL listed)

Width: 65.6"

Height: 65.68"

Length: 82" with conveyor

Shipping Weight: 700lbs.

- Produces up to 900/ 7" Flour Tortillas Per Hour.\*\*
- UL and NSF Approved.

\*\* Tortilla production will vary depending upon diameter and thickness of tortillas and the experience of the equipment operator.\*\*



# 1-800-683-0928

[www.bescomfg.com](http://www.bescomfg.com)

Customize the Beta 900 to fit in your facility choosing from a Right, Left or Straight Exit with different size exit conveyors 30", 42", or 60".

1623 N. San Marcos • San Antonio, TX 78201 • (210) 734-5124 • FAX (210) 737-3925

## Beta 900 and DTL Left Side Exit

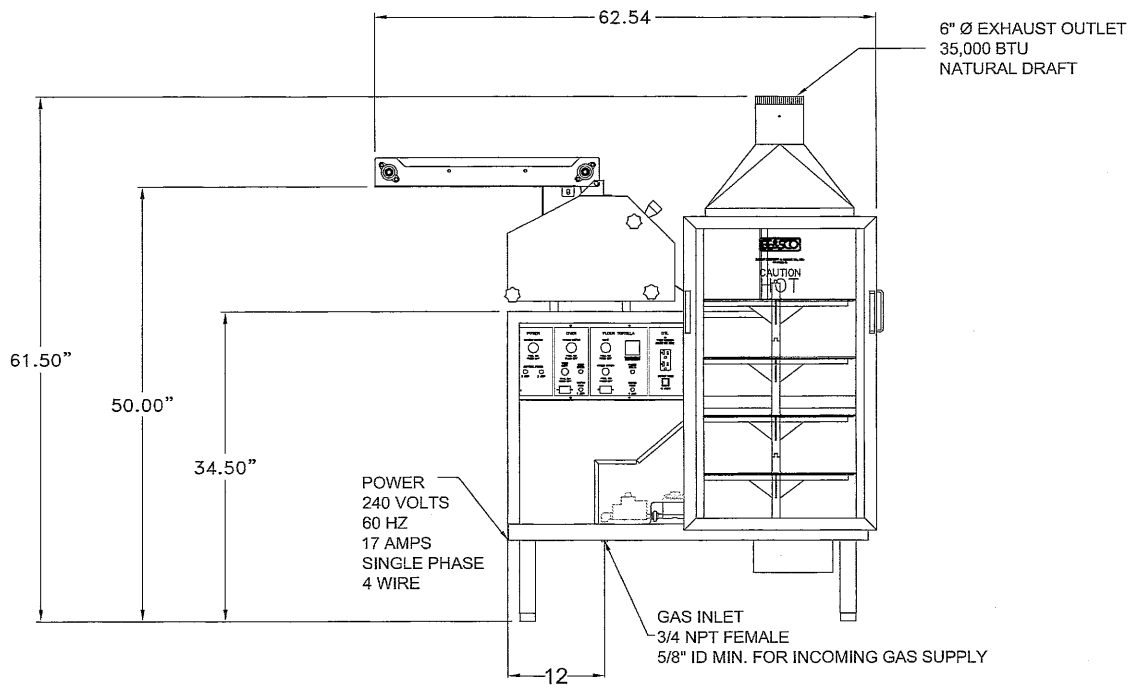
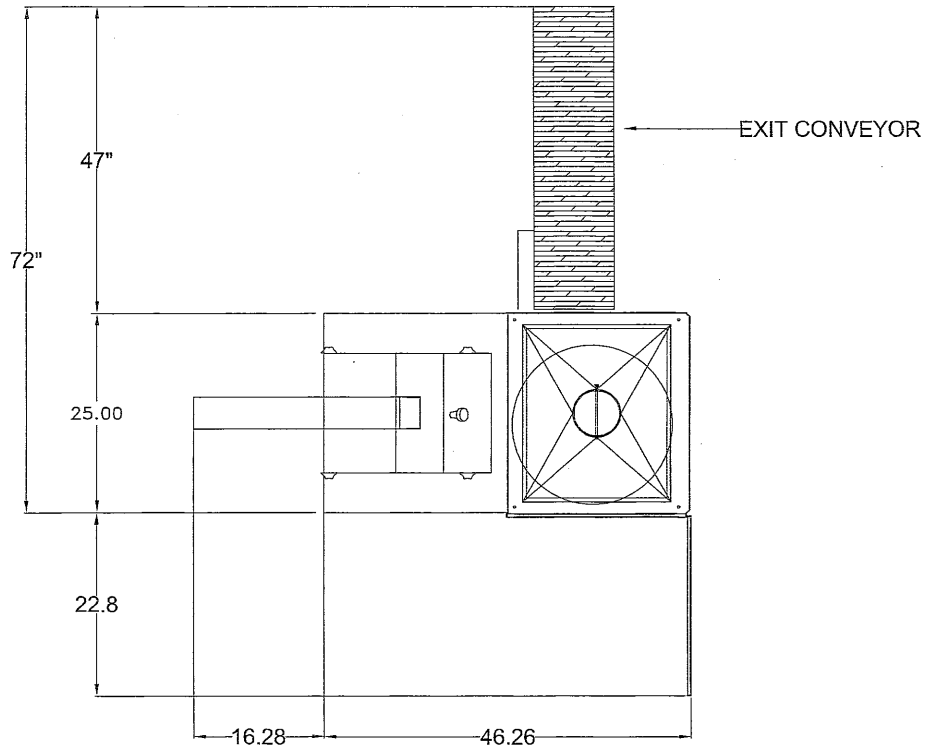

**MODEL : BETA 900 7F-L**

# Beta 900 and DTL Right Side Exit

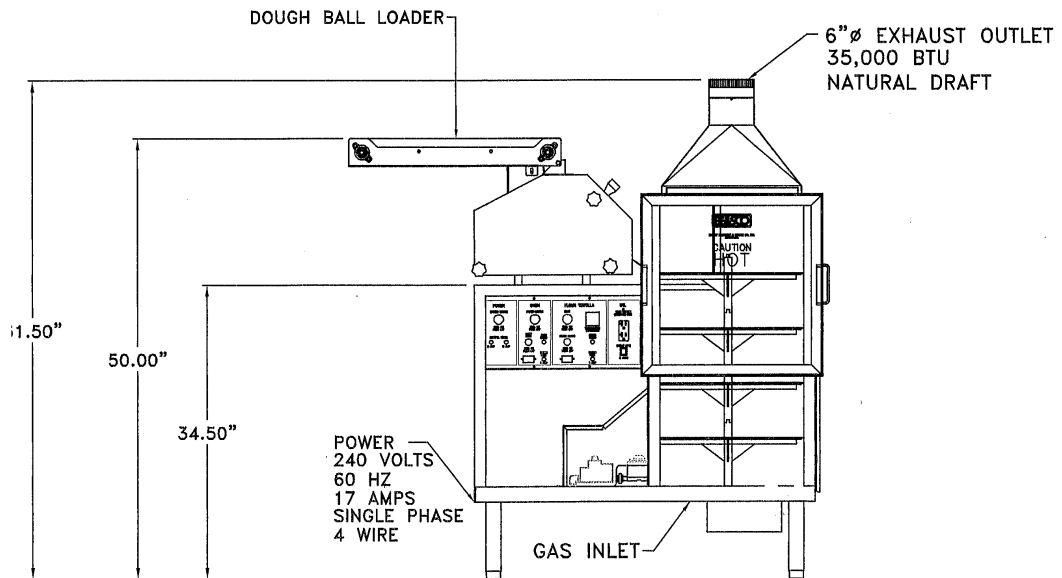
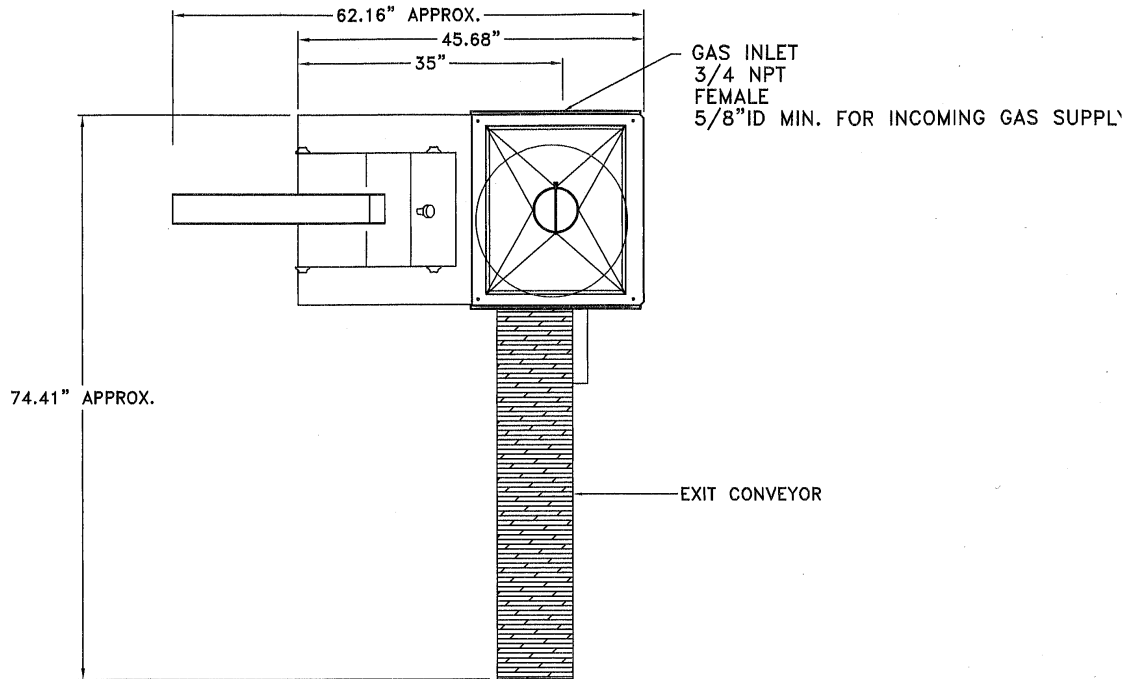

BETA 900 7F-R

# Beta 900 and DTL Straight Exit

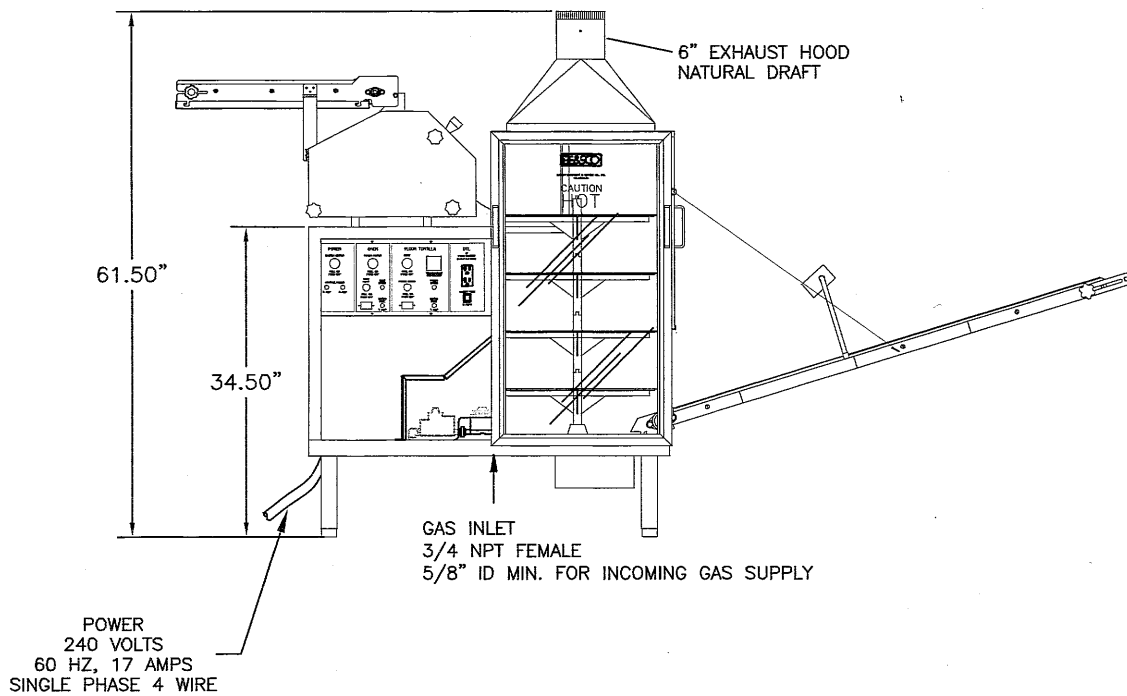
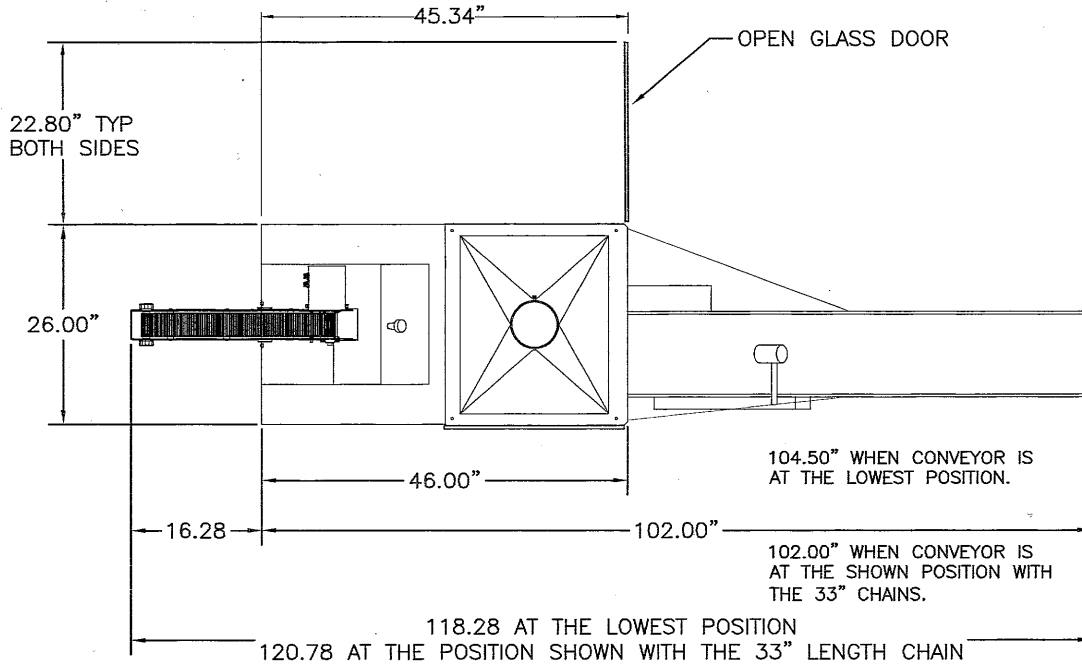

MODEL : BETA 900 7F-S

# Beta 900 Straight Exit

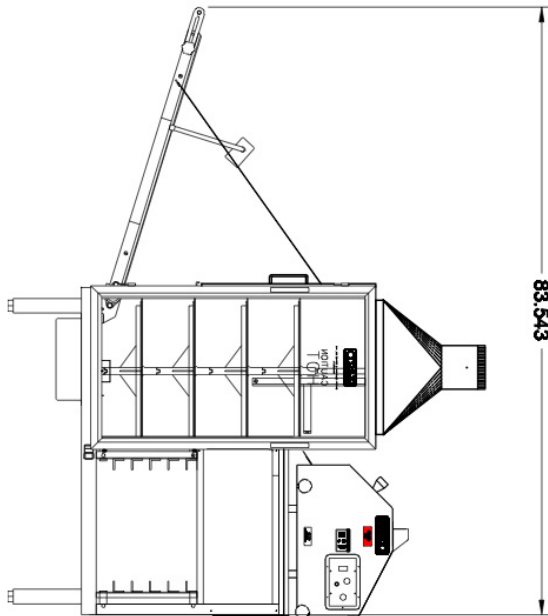
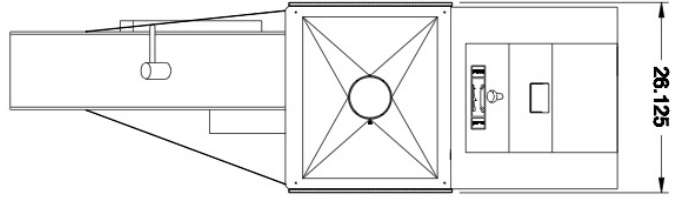
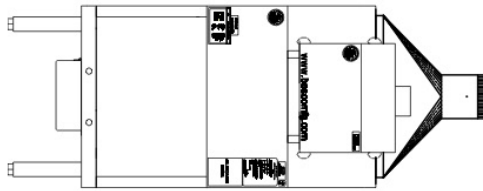
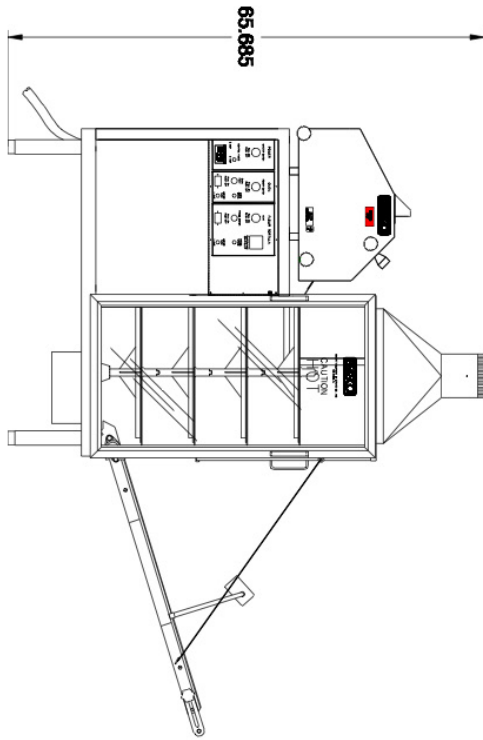

# Beta 900 Left Exit

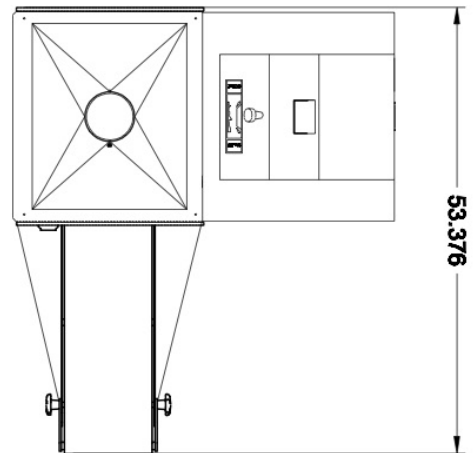
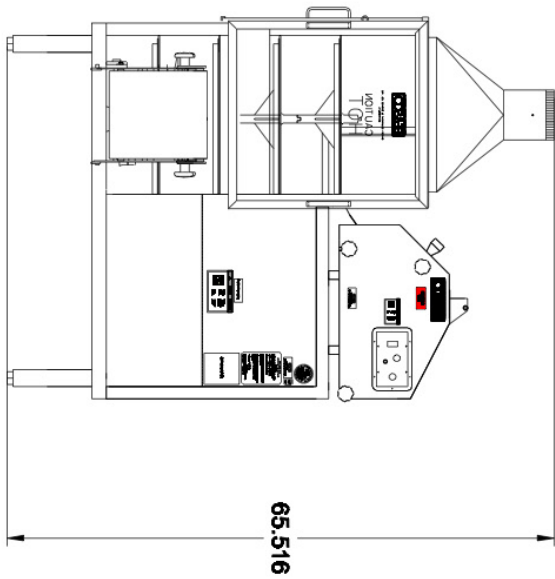
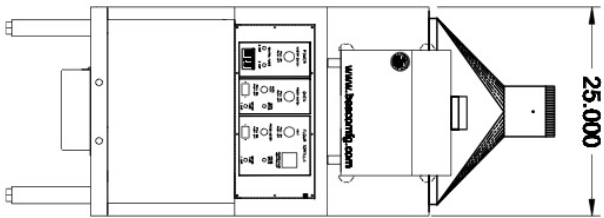
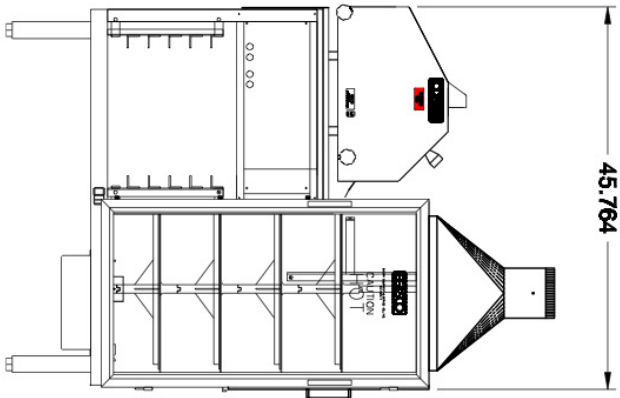

# Beta 900 Right Exit

